

MIRAGE FOR C|24®

●●●●● ARGOSY®

Imagine -  
then transform.



**UNMISTAKABLE** appeal, Mirage has created a bold new standard for combining beauty and function. Each Mirage console provides an inspirational landscape that allows you to escape the trappings of technology and gives you the opportunity to create your best work.

Your dream studio  
just got closer.

Ph: 573.557.3150 toll free: 800.315.0878

# FEATURES AND TECHNICAL SPECIFICATIONS

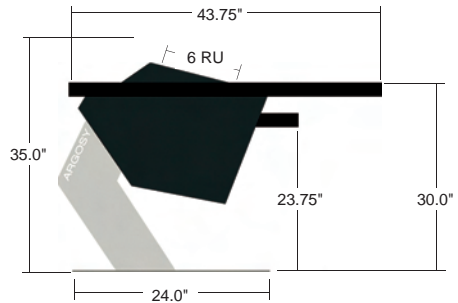
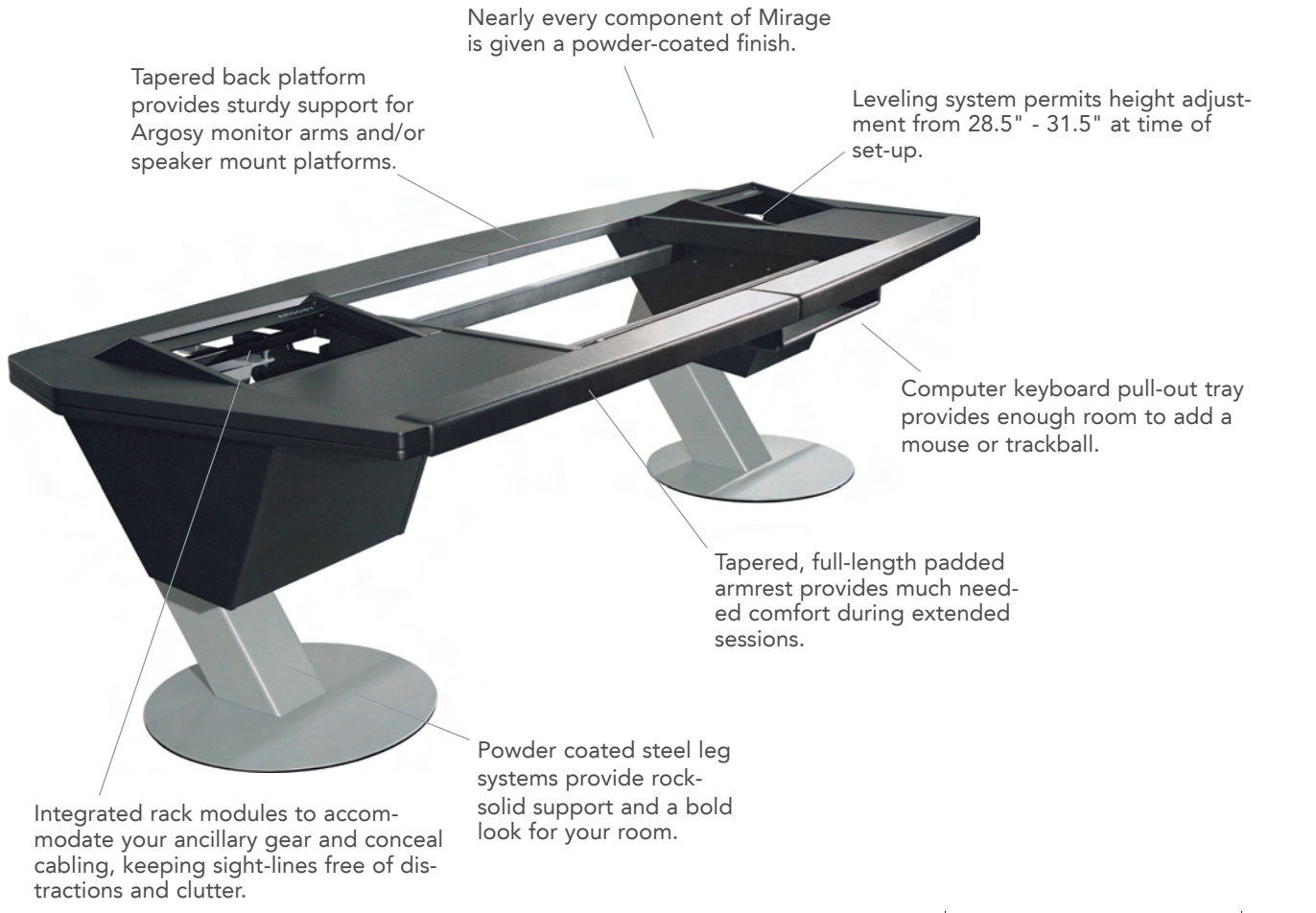

Mirage C|24 Dimensions

Cabling is fully concealed and protected inside leg channels.



## FEATURES AND TECHNICAL SPECIFICATIONS

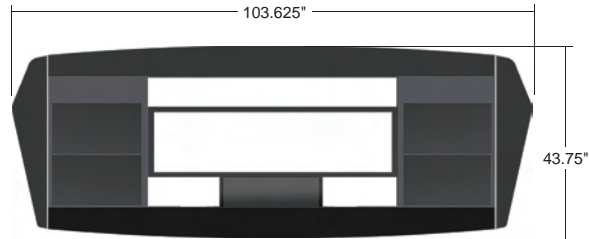

Mirage C|24 Dimensions

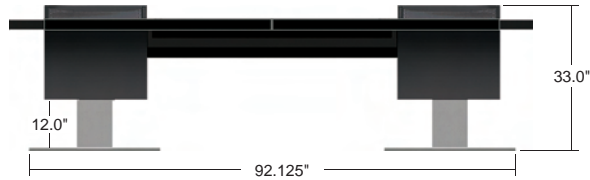

Mirage C|24 Dimensions

**MIRAGE** consoles are palletized and shipped partially assembled for easy installation. Each model design is product specific for the best possible fit. Custom configurations and installation service available.

Chassis components are made of 3 to 14 gauge steel tubing and 19mm and 32mm thermofused and/or powder coated MDF to provide durability, strength, and density for minimal acoustical influence.

Mirage's low profile signature promotes sonic transparency. The open chassis design defeats thermal buildup.

Legs have large channel openings to permit easy cable access through rack support system. Cable pass-throughs in racking systems provide convenient cabling access to mixer and outboard peripheral gear.

## MIRAGE FOR C|24®

**MORE THAN** a functional space for your control surface and electronics, Mirage is an inspirational landscape that inspires and enables you to create your best work.

Custom fit for the AVID® C|24, the Mirage NC24 presents a bold, clean design with a precision fit & finish for the centerpiece of your room.

- Precision Fit and Finish
- Tubular Steel Chassis
- Powder Coated Components
- Padded Armrest
- Trim Options

### ACCESSORIES



Mahogany  
Hardwood  
Endpanels



Rack Rail  
Screws



Monitor  
Arms



Speaker  
Platforms

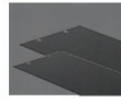

Blank Panels



### NEED A CUSTOMIZED SOLUTION?

Give us a call to discuss what you have in mind, we're happy to help.

### WARRANTY

ARGOSY WARRANTS ALL MATERIALS AND WORKMANSHIP TO BE FREE OF DEFECTS FOR A PERIOD OF ONE YEAR.

For more information about our products and services or to see a list of dealers, please visit us at [www.argosyconsole.com](http://www.argosyconsole.com) or call the numbers below.

©2010 ARGOSY CONSOLE, INC. All rights reserved. Argosy is a registered trademark of Argosy Console, Inc. Other trademarked names are the property of their respective owners.

Ph: 573.557.3150 toll free: 800.315.0878